

Coupling description

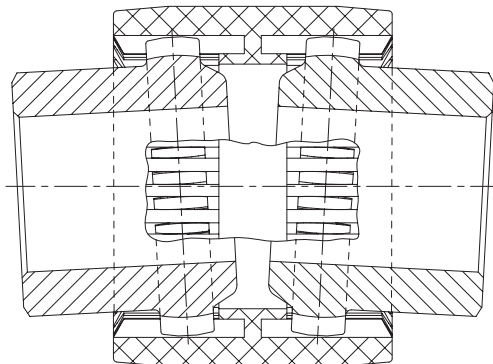

General description:

BoWex® – couplings are designed to transmit torque between drive and driven components via curved tooth hubs and a nylon sleeve. The combination of these components provides a torsionally stiff connection and accommodation for misalignments. This product is available in materials and elements that are optimized for close coupled applications.

Function and Design

BoWex® - couplings, suitable for horizontal or vertical applications, are constructed from a variety of materials providing a torsionally stiff platform optimizing the balance between coupling performance and application requirements. The double-crowned tooth reduces edge loading while accommodating misalignments and transmitting torque. The symmetrical relationship of the hubs and floating nylon sleeve allows for minimal maintenance in a close coupled design.

The design of the BoWex® allows the nylon sleeve to float independently of the two hubs thus minimizing restoring forces. The result is a double-cardanic coupling with high torsional stiffness, low inertia and chemical resistance while accommodating large axial movement. Unlike other gear couplings, BoWex® does not require lubrication and can be used for shaft to shaft and engine flywheel drive applications.

BoWex® is available in a variety of standard mounting options to accommodate shafts up to 4.813 inches and a maximum nominal torque of 22,120 lb-in while still accommodating blind assembly. As defined by the sleeve, BoWex® couplings are suitable for moderate industrial temperature ranges. All these design features reduce the maintenance required during the life-cycle of the coupling.

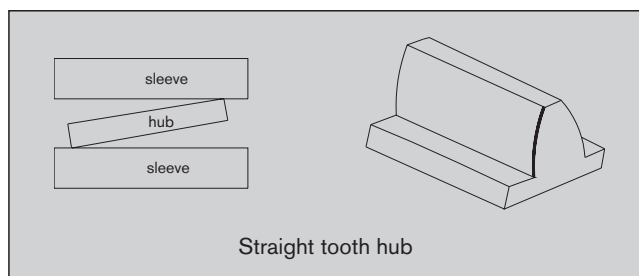

On couplings with straight teeth, high edge pressure contributes to considerable wear at the contact surfaces when misalignment is present.

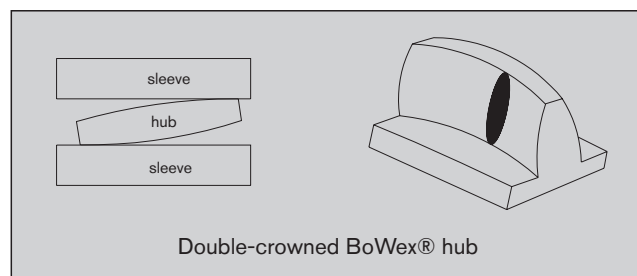

The curved teeth avoid any edge pressure on the coupling when angular and radial misalignments occur.

Explosion-proof use

BoWex® couplings design M up to size 65 including an electrically conductive nylon sleeve (PA-CF) are suitable for power transmission in drives in hazardous areas. The couplings are certified and conform to EC standard 94/9/EC (ATEX 95) as units of category 2G/2D and thus suitable for the use in hazardous areas of zone 1, 2, 21 and 22. Please read through our information included in the Type Examination Certificate and the operating and installation instructions at www.ktr.com



Technical data

Power, Torque and Speed							
Design and size		Power $\frac{P \text{ [HP]}}{n \text{ [rpm]}}$		Torque T_K [lb-in]			Max. speed [rpm]
		Rated	Maximum	T_{KN}	$T_{K \text{ max.}}$	T_{KW}	
Type plug-in coupling / junior M	junior 14 / M-14	0.0007	0.0134	44	89	22	6,000
	junior 19 / M-19	0.0011	0.0023	71	140	35	6,000
	junior 24 / M-24	0.0017	0.0034	106	210	53	6,000
Type M I AS Spec.-I SG SSR	14	0.0013	0.0040	89	260	44	14,000
	19	0.0023	0.0067	140	420	71	11,800
	24	0.0028	0.0080	170	530	89	10,600
	28	0.0063	0.0188	390	1,190	200	8,500
	32	0.0084	0.0255	530	1,590	260	7,500
	38	0.0113	0.0335	700	2,120	350	6,700
	42	0.0134	0.0415	880	2,650	440	6,000
	45 / 48	0.0201	0.0590	1,230	3,710	610	5,600
	65	0.0536	0.1595	3,360	10,090	1,680	4,000
	80	0.0978	0.2948	6,190	18,580	3,090	3,150
	100	0.1742	0.5092	10,620	31,860	5,310	3,000
	125	0.3484	1.0452	22,120	66,380	11,060	2,120
Type M...C	14	0.0020	0.0063	130	390	66	14,000
	19	0.0034	0.0101	210	630	100	11,800
	24	0.0040	0.0121	260	790	130	10,600
	28	0.0094	0.0295	610	1,850	300	8,500
	32	0.0121	0.0375	790	2,380	390	7,500
	38	0.0174	0.0509	1,060	3,180	530	6,700
	48	0.0281	0.0844	1,770	5,310	880	5,600
	65	0.0777	0.2412	4,950	14,860	2,470	4,000
Type FLE-PA	48	0.0335	0.0670	2,120	5,310	1,060	5,000
	T 48	0.0402	0.1045	2,650	6,630	1,320	5,000
	T 55	0.0630	0.1611	3,980	9,950	1,990	4,500
	65	0.0911	0.1876	5,750	14,160	2,870	3,600
	T 65	0.1126	0.2814	7,080	17,700	3,540	3,600
	T 70	0.1407	0.3511	8,850	22,120	4,420	3,400
	80	0.1742	0.3350	10,620	26,550	5,310	3,000
	T 80	0.2144	0.0523	13,270	33,190	6,630	3,000
	100	0.2814	0.5762	18,140	45,580	9,070	2,500
	T 100	0.3484	0.8710	22,120	55,310	11,060	2,500
	125	0.5896	1.1926	37,610	94,700	18,800	2,500
	Type ELASTIC HE HEW HEW-ZS HE-ZS HEG	40Sh	0.0188	0.0549	1,150	3,450	310
42 HE 50Sh		0.0214	0.0630	1,320	3,980	390	6,200
65Sh		0.0255	0.0764	1,590	4,770	470	
40Sh		0.0281	0.0844	1,770	5,310	530	
48 HE 50Sh		0.0322	0.0965	2,030	6,100	610	5,600
65Sh		0.0389	0.1179	2,470	7,430	740	
40Sh		0.0496	0.1474	3,090	9,290	920	
65 HE 50Sh		0.0563	0.1688	3,540	10,620	1,060	4,500
65Sh		0.0697	0.2104	4,420	13,270	1,320	
40Sh		0.0603	0.1809	3,800	11,410	1,140	
G 65 HE 50Sh		0.0697	0.2104	4,420	13,270	1,320	4,300
65Sh		0.0871	0.2613	5,480	16,460	1,640	
40Sh		0.1193	0.3578	6,630	19,910	1,990	
80 HE 50Sh		0.1286	0.3993	8,400	25,220	2,520	3,600
65Sh		0.1688	0.4985	10,620	31,860	3,180	
40Sh		0.1742	0.5226	11,060	33,190	3,310	
G 80 HE 50Sh		0.2144	0.6700	14,160	42,480	4,240	3,000
65Sh		0.2814	0.8308	17,700	53,100	5,310	
40Sh		0.2814	0.8308	17,700	53,100	5,310	
100 HE 50Sh		0.3484	1.0452	22,120	66,380	6,630	2,700
65Sh		0.4824	1.3400	28,320	84,960	8,490	
40Sh		0.4154	1.2623	26,550	79,650	7,960	
125 HE 50Sh		0.5494	1.6830	35,400	106,210	10,620	2,300
70Sh		0.6968	2.1038	44,250	132,760	13,270	
40Sh		0.5628	1.6884	35,400	106,210	10,620	
G 125 HE 50Sh		0.7236	2.1842	46,020	141,610	14,160	2,100
70Sh		0.9112	2.7336	57,530	177,020	17,700	
40Sh		0.7772	2.3182	48,680	146,040	14,600	
150 HE 50Sh		0.9782	2.9480	61,950	185,870	18,580	1,800
70Sh		1.2596	3.7922	79,650	238,970	23,890	

Coupling selection

The BoWex® coupling is selected in accordance with DIN 740 part 2. The coupling must be selected so that the allowable coupling load is not exceeded in any operating condition. For this reason, the actual loads must be compared to the capacities of the coupling.

1 Drives without alternating torque

The coupling is selected by checking the rated torques T_{KN} and maximum torque $T_{K \max}$.

2 Load produced by engine rated torque

$$T_{KN} \leq T_N \cdot S_t$$

Taking the ambient temperature into consideration, the rated torque T_{KN} of the coupling must be greater than or equal to the rated torque T_N of the application

$$T_N [\text{lb-in}] = 63,025 \cdot \frac{P_{AN}[\text{HP}]}{n_{AN} [\text{rpm}]}$$

3 Load produced by torque shocks

$$T_{K \max} \leq T_S \cdot S_Z \cdot S_t + T_N \cdot S_t$$

The maximum torque of the coupling must equal to at least the total of peak torque T_S and the rated torque T_N of the machine, taking into account the shock frequency Z and the ambient temperature.

Drive-sided shock
 $T_S = T_{AS} \cdot M_A \cdot S_A$

Load-sided shock
 $T_S = T_{LS} \cdot M_L \cdot S_L$

$$M_A = \frac{J_L}{J_A + J_L} \quad M_L = \frac{J_A}{J_A + J_L}$$

This applies if the rated torque T_N of the machine is also subject to shocks.

The peak torque T_S can be calculated if the mass distribution, shock direction and shock mode are known.

For drives with A. C.-motors and high masses on the load side we recommend that you call KTR to assist you in calculating the peak driving torque.

Allowable load on the hub keyway

The shaft hub connection has to be reviewed by the customer. Allowable surface pressure according to DIN 6892 (method C).

Description	Symbol	Definition or explanation
Rated torque of coupling	T_{KN}	Torque that can continuously be transmitted over the entire permissible speed range.
Maximum torque of coupling	$T_{K \max}$	Torque that can be transmitted as dynamic load $\leq 10^5$ times or 5×10^4 as vibratory load, respectively, during the entire operating life of the coupling.
Vibratory torque of coupling	T_{KW}	Torque amplitude of the permissible periodical torque fluctuation with a frequency of 10 Hz and a basic load of T_{KN} or dynamic load up to T_{KN} , respectively.
Damping power of coupling	P_{KW}	Permissible damping power with an ambient temperature of + 86 °F.
Rated torque of machine	T_N	Stationary rated torque on the coupling
Peak torque of machine	T_S	Peak torque on the coupling
Peak torque on the driving side	T_{AS}	Peak torque with torque shock on the driving side, e. g. breakdown torque of the electric motor.

Service factor S_t for temperature

Material of sleeve	-40 °F +140 °F	+158 °F	+176 °F	+194 °F	+212 °F	+230 °F	+248 °F
PA 6.6	1.0	1.2	1.4	1.6	1.8	-	-
PA-CF	1.0	1.1	1.2	1.4	1.6	1.9	2.2

Service factor S_Z for starting frequency

starting frequency/h	100	200	400	800
S_Z	1.0	1.2	1.4	1.6

Service factor S_A/S_L for shocks

	S_A/S_L
gentle shocks	1.5
average shocks	1.8
heavy shocks	2.5

Polyamide 4,300 psi (up to + 104 °F)
Sintered metal 26,000 psi
Material steel 36,000 psi
for other steel materials $p_{perm.} = 0,9 \cdot R_e (R_{p0,2})$

Description	Symbol	Definition or explanation
Peak torque of load side	T_{LS}	Peak torque with torque shock on load side, e. g. braking.
Vibratory torque of machine	T_{W}	Amplitude of the vibratory torque effective on the coupling.
Damping power of the machine	P_{W}	Damping power which is effective on the coupling due to the load produced by the vibratory torque.
Moment of inertia of driving side	J_A	Total of moments of inertia existing on the driving or load side referring to the coupling speed.
Moment of inertia of load side	J_L	
Rotational inertia coefficient of driving side	M_A	Factor taking into account the mass distribution with shocks and vibrations produced on the driving or load side.
Rotational inertia coefficient of load side	M_L	$M_A = \frac{J_L}{J_A + J_L} \quad M_L = \frac{J_A}{J_A + J_L}$

Misalignments and setscrew threads

Misalignments

BoWex® couplings are double-cardanic (2 flex-points). In addition to transmitting torque, they compensate for axial, parallel and angular shaft misalignments. This prevents damage from the driving or driven machine.

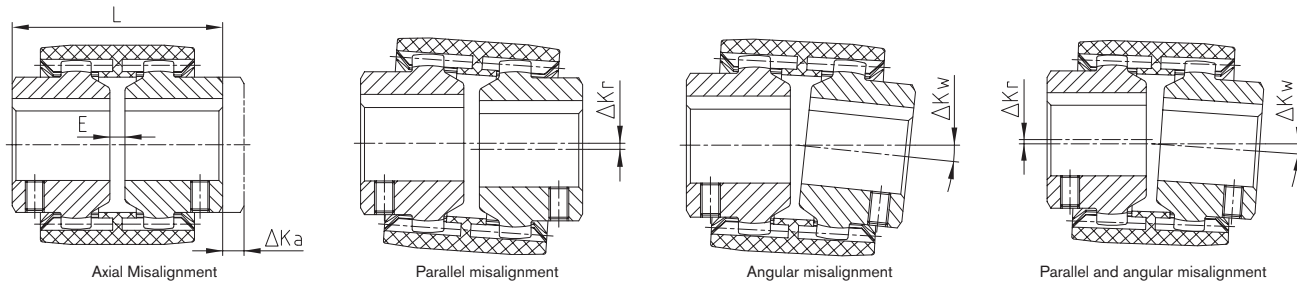

Misalignment						
BoWex® size	Type junior plug-in coupling			Type junior M		
	14	19	24	14	19	24
Maximum axial misalignment ΔKa [in]	± 0.040	± 0.040	± 0.040	± 0.040	± 0.040	± 0.040
1500 rpm						
Maximum parallel misalignment ΔKr [°]	± 0.040	± 0.040	± 0.040	± 0.012	± 0.012	± 0.016
Maximum angular misalignment ΔKw [°]	± 0.040	± 0.040	± 0.035	± 0.040	± 0.040	± 0.035
3000 rpm						
Maximum parallel misalignment ΔKr [°]	± 0.040	± 0.040	± 0.040	± 0.012	± 0.012	± 0.016
Maximum angular misalignment ΔKw [°]	± 0.028	± 0.028	± 0.024	± 0.028	± 0.028	± 0.024

Misalignment												
BoWex® size	14	19	24	28	32	38	42	48	65	80	100	125
Maximum axial misalignment ΔKa [in]	± 0.040	± 0.040	± 0.040	± 0.040	± 0.040	± 0.040	± 0.040	± 0.040	± 0.040	± 0.040	± 0.040	± 0.040
1500 rpm												
Maximum parallel misalignment ΔKr [°]	± 0.012	± 0.012	± 0.014	± 0.014	± 0.014	± 0.016	± 0.016	± 0.016	± 0.018	± 0.018	± 0.018	± 0.018
Maximum angular misalignment ΔKw [°]	± 0.040	± 0.040	± 0.035	± 0.035	± 0.035	± 0.035	± 0.035	± 0.035	± 0.028	± 0.028	± 0.024	± 0.016
3000 rpm												
Maximum parallel misalignment ΔKr [°]	± 0.008	± 0.008	± 0.009	± 0.009	± 0.009	± 0.010	± 0.010	± 0.010	± 0.011	± 0.011	± 0.011	± 0.011
Maximum angular misalignment ΔKw [°]	± 0.028	± 0.028	± 0.024	± 0.024	± 0.024	± 0.024	± 0.024	± 0.024	± 0.020	± 0.016	± 0.016	± 0.012

The assembled hubs must always be flush with the shaft ends. If it is difficult to determine the distance dimension "E", reference may be made to the overall assembled length.

The shaft ends to be connected should be supported close to each coupling half.

- 1) The listed distance dimension "E" must be observed in every case, particularly for parallel and angular misalignments.
- 2) If the coupling hubs have been shortened or lengthened on the outside, the overall length of the coupling assembled will be reduced by the corresponding figure.
- 3) The allowable misalignment figures depend on speed and performance.

Prior to operation of the BoWex® coupling please make sure that the coupling sleeves are capable of axial movement.

The customer must provide guards in order to ensure that rotating parts cannot cause injury (Safety of Machines, DIN EN 292 part 2).

Setscrew dimensions (BoWex® coupling hubs with straight bores.)

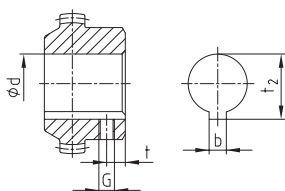

Position of the thread for setscrews

BoWex® M-14 to M-24 opposite the keyway

BoWex® M-28 to I-125 on the keyway

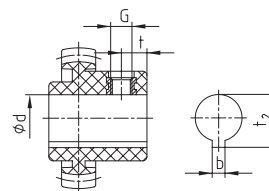

Position of the thread for BoWex®

Junior plug-in coupling and junior M-coupling

BoWex® – coupling hubs							
Size	14	28	42				
Dimensions	19	32	45	65	80	100	125
Thread G	M5	M8	M10	M10	M12	M16	
Distance t	0.24	0.39	0.59	0.79	1.18	1.57	
			0.79				
Tightening torque TA [lb-in]	18	89	150	150	150	700	

BoWex® junior – coupling hubs			
Size	14	19	24
Dimensions			
Thread G	M5	M5	M5
Hub 1b - Distance t	0.24	0.24	0.24
Plug-in sleeve 2b - Distance t	0.31	0.39	0.39
Tightening torque TA [lb-in]	12	12	12

1) Hub length 2.16" t = 0.59", 2.75" t = 0.79"

BoWex® Curved-tooth gear couplings



BoWex® part numbers

Part Number Pages to follow

Notes:

BoWex®
MONOLASTIC®
BoWex® - FL-PA
BoWex® - ELASTIC®

BoWex® Part Numbers

BoWex Hubs - Part numbers by product size and standard material						
Inch Sizes		14	19	24	28	32
Bore	Keyway	Sintered Steel				
5/16	No Key	BA010142070711				
3/8	No Key	BA010142070911				
3/8	3/32	BA010142070902				
3/8	1/8	BA010142070903				
7/16	No Key	BA010142071111	BA010192071111	BA010242071111		
7/16	3/32	BA010142071101	BA010192071101	BA010242071101		
7/16	1/8	BA010142071102	BA010192071102	BA010242071102		
1/2	No Key	BA010142071211	BA010192071211	BA010242071211		
1/2	1/8	BA010142071200	BA010192071200	BA010242071200	BA010282071200	
9/16	No Key	BA010142071411	BA010192071411	BA010242071411	BA010282071411	
9/16	1/8	BA010142071400	BA010192071400	BA010242071400	BA010282071400	
5/8	No Key		BA010192071511	BA010242071511	BA010282071511	
5/8	3/32		BA010192071501	BA010242071501	BA010282071501	
5/8	5/32		BA010192071503	BA010242071503	BA010282071503	
5/8	3/16		BA010192071500	BA010242071500	BA010282071500	BA010322071500
11/16	3/16		BA010192071700	BA010242071700	BA010282071700	BA010322071700
3/4	No Key		BA010192071911	BA010242071911	BA010282071911	BA010322071911
3/4	1/8		BA010192071901	BA010242071901	BA010282071901	BA010322071901
3/4	3/16		BA010192071900	BA010242071900	BA010282071900	BA010322071900
13/16	3/16			BA010242072000	BA010282072000	BA010322072000
7/8	No Key			BA010242072211	BA010282072211	BA010322072211
7/8	3/16			BA010242072200	BA010282072200	BA010322072200
7/8	1/4			BA010242072202	BA010282072202	BA010322072202
15/16	1/4			BA010242072300	BA010282072300	BA010322072300
1	1/4				BA010282072500	BA010322072500
1	3/16				BA010282072502	BA010322072502
1 1/16	1/4				BA010282072600	BA010322072600
1 1/8	1/4				BA010282072800	BA010322072800
1 3/16	1/4					BA010322073000
1 1/4	1/4					BA010322073100
1 1/4	5/16					BA010322073102

Inch bores machined to AGMA Class 1

All hubs supplied standard with one setscrew

Non standard bores available. Consult KTR Engineering

BoWex Sleeves - Part numbers by product size and material						
Type	Material	14	19	24	28	32
M	PA	010141000000	010191000000	010241000000	010281000000	010321000000
M...C	carbon fiber reinforced PA	010141000005	010191000005	010241000005	010281000005	010321000005
AS	PA			010241000020	010281000020	010321000020
Spec - I	PA			010241000030	010281000030	010321000030

BoWex® Part Numbers

BoWex Hubs - Part numbers by product size and standard material						
Bore	Metric Key	14	19	24	28	32
		Sintered Steel				
8	2	BA010142000800				
9	3	BA010142000900				
10	3	BA010142001000	BA010192001000	BA010242001000		
11	4	BA010142001100	BA010192001100	BA010242001100		
12	4	BA010142001200	BA010192001200	BA010242001200		
14	5	BA010142001400	BA010192001400	BA010242001400	BA010282001400	
15	5	BA010142001500	BA010192001500	BA010242001500	BA010282001500	
16	5		BA010192001600	BA010242001600	BA010282001600	
18	6		BA010192001800	BA010242001800	BA010282001800	BA010322001800
19	6		BA010192001900	BA010242001900	BA010282001900	BA010322001900
20	6		BA010192002000	BA010242002000	BA010282002000	BA010322002000
22	6			BA010242002200	BA010282002200	BA010322002200
24	8			BA010242002400	BA010282002400	BA010322002400
25	8				BA010282002500	BA010322002500
28	8				BA010282002800	BA010322002800
30	8					BA010322003000
32	10					BA010322003200

Metric bores machined to H7

BoWex® Part Numbers

BoWex Hubs - Part numbers by product size and standard material							
Inch Sizes		38	42	48	65	80	
Bore	Keyway	Sintered Steel				Steel	
3/4	No Key	BA010382071911					
3/4	1/8	BA010382071901					
3/4	3/16	BA010382071900	BA010422061903				
13/16	3/16	BA010382072000	BA010422062004				
7/8	No Key	BA010382072211	BA010422062210				
7/8	3/16	BA010382072200	BA010422062202	BA010482072200			
7/8	1/4	BA010382072202	BA010422062203	BA010482072202			
15/16	1/4	BA010382072300	BA010422062301	BA010482072300			
1	1/4	BA010382072500	BA010422062502	BA010482072500	BA010652072500		
1 1/16	1/4	BA010382072600	BA010422062602	BA010482072600	BA010652072600		
1 1/8	1/4	BA010382072800	BA010422062802	BA010482072800	BA010652072800		
1 3/16	1/4	BA010382073000	BA010422063002	BA010482073000	BA010652073000		
1 1/4	1/4	BA010382073100	BA010422063102	BA010482073100	BA010652073100		
1 1/4	5/16	BA010382073102	BA010422063103	BA010482073102	BA010652073102		
1 5/16	5/16	BA010382073300	BA010422063302	BA010482073300	BA010652073300		
1 3/8	5/16	BA010382073400	BA010422063402	BA010482073400	BA010652073400		
1 3/8	3/8	BA010382073401	BA010422063403	BA010482073401	BA010652073401		
1 7/16	3/8	BA010382073600	BA010422063602	BA010482073600	BA010652073600		
1 1/2	5/16		BA010422063803	BA010482073802	BA010652073802		
1 1/2	3/8		BA010422063802	BA010482073800	BA010652073800		
1 9/16	3/8		BA010422063902	BA010482073900	BA010652073900		
1 5/8	3/8		BA010422064102	BA010482074100	BA010652074100		
1 11/16	3/8			BA010482074200	BA010652074200		
1 3/4	3/8			BA010482074400	BA010652074400		
1 3/4	7/16			BA010482074402	BA010652074402		
1 13/16	1/2			BA010482074600	BA010652074600		
1 7/8	1/2			BA010482074700	BA010652074700		
1 15/16	1/2				BA010652074900		
2	1/2				BA010652075000	BA010805075000	
2 1/16	1/2				BA010652075200	BA010805075200	
2 1/8	1/2				BA010652075300	BA010805075300	
2 3/16	1/2				BA010652075500	BA010805075500	
2 1/4	1/2				BA010652075700	BA010805075700	
2 3/8	5/8				BA010652076000	BA010805076000	
2 5/8	5/8					BA010805076600	
2 7/8	3/4					BA010805077300	
2 15/16	3/4					BA010805077400	
3	3/4					BA010805077600	
3 1/16	3/4					BA010805077700	
3 1/8	3/4					BA010805077900	

Inch bores machined to AGMA Class 1
All hubs supplied standard with one setscrew
Non standard bores available. Consult KTR Engineering

BoWex Sleeves - Part numbers by product size and material							
Type	Material	38	42	45	48	65	80
M / I	PA	010381000000	010421000000		010481000000	010651000000	010801000015
M...C	carbon fiber reinforced PA	010381000005	010421000005		010481000005	010651000005	
AS	PA			010451000020		010651000020	010801000020
Spec - I	PA			010451000030		010651000030	010801000030

BoWex® Part Numbers

BoWex Hubs - Part numbers by product size and standard material						
Bore	Metric Key	38	42	48	65	80
		Sintered Steel				
18	6	BA010382001800				
19	6	BA010382001900				
20	6	BA010382002000	BA010422062001			
22	6	BA010382002200	BA010422062201			
24	8	BA010382002400	BA010422062401			
25	8	BA010382002500	BA010422062501	BA010482002500		
28	8	BA010382002800	BA010422062801	BA010482002800		
30	8	BA010382003000	BA010422063001	BA010482003000	BA010652003000	
32	10	BA010382003200	BA010422063201	BA010482003200	BA010652003200	
35	10	BA010382003500	BA010422063501	BA010482003500	BA010652003500	
38	10	BA010382003800	BA010422063801	BA010482003800	BA010652003800	
40	12		BA010422064001	BA010482004000	BA010652004000	
42	12		BA010422064201	BA010482004200	BA010652004200	
45	14			BA010482004500	BA010652004500	
48	14			BA010482004800	BA010652004800	
50	14				BA010652005000	
55	16				BA010652005500	BA010805005500
60	18				BA010652006000	BA010805006000
65	18				BA010652006500	BA010805006500
70	20					BA010805007000
75	20					BA010805007500

Metric bores machined to H7
All hubs supplied standard with one setscrew
Non standard bores available. Consult KTR Engineering

All nylon junior plug-in coupling and junior M design

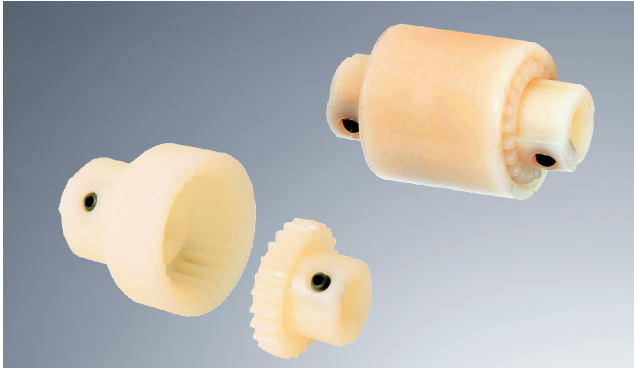

- 1 Non-failsafe, reduced maintenance, blind assembly
- 1 Corrosion resistant all polyamide construction
- 1 Torsionally stiff
- 1 Low inertia
- 1 Compact design for short shaft gaps
- 1 Installation instructions available at www.ktr.com

Components

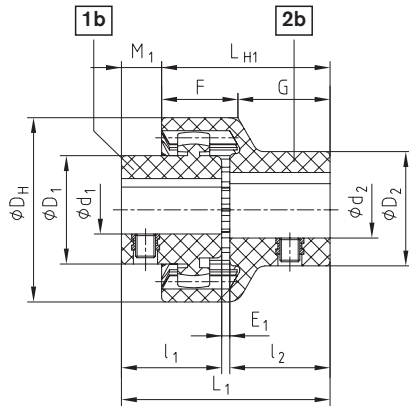

Design junior plug-in coupling (2 piece)

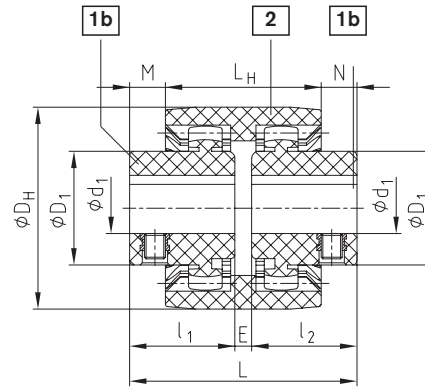

Design junior M coupling (3 piece)

BoWex® junior plug-in coupling (2 parts) and BoWex® junior M (3 parts)

Size	Torque		Available bore			Dimensions [in]											Max. speed [rpm]		
	T_K [lb-in]		Hub part 1b d_1	Plug-in-sleeve part 2b d_2	D_2	D_H	l_1, l_2	E_1	L_1	L_{H1}	M_1	F	G	E	L	L_H		M, N	
	T_{KN}	$T_{Kmax.}$																	
14	44	89	0.236, 0.276, 0.315, 0.354	0.87	0.315	0.87	1.57	0.91	0.08	1.89	1.57	0.31	0.73	0.85	0.16	1.97	1.46	0.26	6,000
M-14			0.394, 0.433	0.98	0.394, 0.433	0.98													
			0.472, 0.551	1.02	0.472, 0.551	1.02													
19	71	142	0.472, 0.551	1.06	0.551, 0.591	1.14	1.85	0.98	0.08	2.05	1.65	0.39	0.75	0.91	0.16	2.13	1.46	0.33	6,000
M-19			0.630	1.18	0.551, 0.591	1.14													
			0.748	1.26	0.748	1.38													
24	106	212	0.394, 0.433, 0.472	1.02	0.551, 0.630	1.26	2.09	1.02	0.08	2.13	1.77	0.35	0.85	0.93	0.16	2.20	1.61	0.30	6,000
M-24			0.551, 0.591, 0.630	1.26	0.551, 0.630	1.26													
			0.709, 0.748, 0.787	1.42	0.748, 0.787	1.42													
			0.945	1.50	0.945	1.57													

Inch bores machined to AGMA Class 1, Metric bores machined to H7

Order form:

BoWex® junior 19	$d_1 \text{ } \varnothing 19$	$d_2 \text{ } \varnothing 14$
Coupling size 2-parted design or BoWex® junior M-19 3-parted type	Bore	Bore

Design M, design I and design M...C

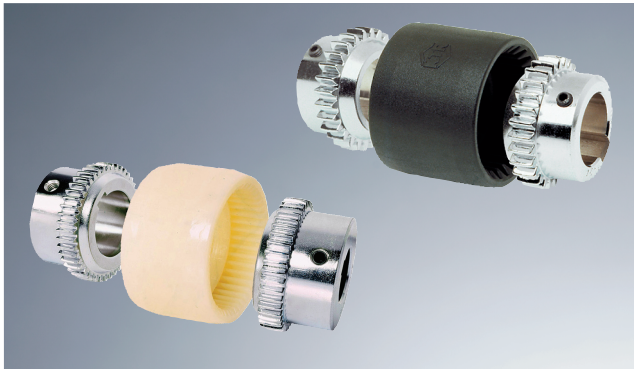

- 1 Non-failsafe, reduced maintenance, blind assembly
- 1 Torsionally stiff
- 1 Suitable for general drive applications
- 1 Compact design for short shaft gaps
- 1 Design MC with carbon fiber reinforced PA sleeve, low backlash, and higher torques. ATEX approved according to EC Standard 94/9/EC (Explosion Certificate ATEX 95)
- 1 Installation instructions available at www.ktr.com

Components

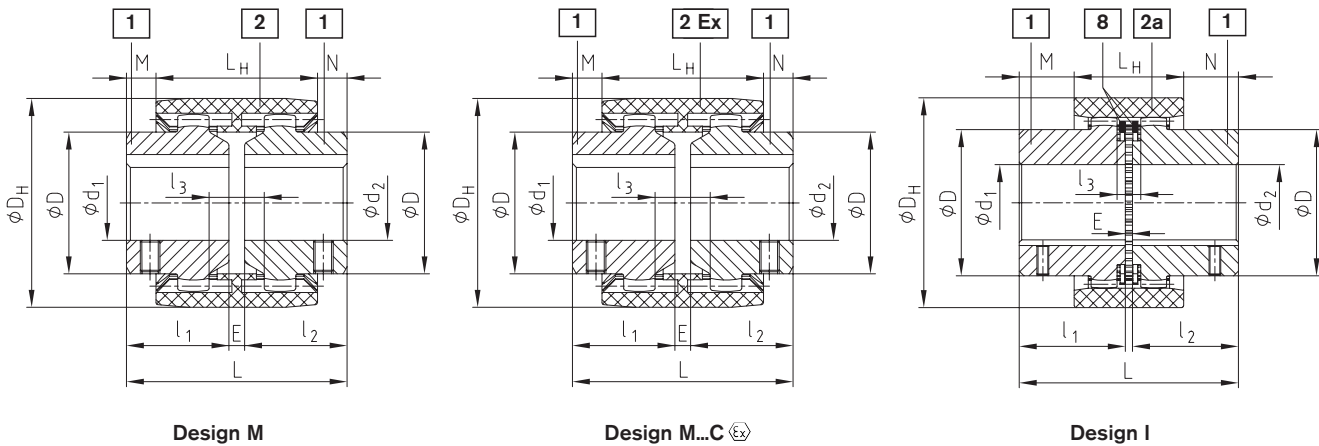

BoWex® design M, design I and design M...C (Ex)																			
Size	Bore d ₁ , d ₂	Dimensions [in]											Weight with max. bore-Ø			Massmoment of inertia J with max. bore-Ø			
		Pilot bored	max.	l ₁ , l ₂	E	L	L _H	M, N	l ₃	D	D _H	Tip circle ØD _Z of hub	Leng- thened l ₁ , l ₂ max.	Sleeve [lb]	Hub [lb]	Total [lb]	Sleeve [lb-in- sec ²]	Hub [lb-in- sec ²]	Total [lb-in-sec ²]
M-14	M-14C	-	0.563	0.91	0.16	1.97	1.46	0.26	0.39	0.98	1.57	1.30	1.57	0.07	0.15	0.22	0.0001	0.0001	0.0002
M-19	M-19C	-	0.813	0.98	0.16	2.13	1.46	0.33	0.39	1.26	1.85	1.54	1.57	0.07	0.22	0.51	0.0001	0.0001	0.0004
M-24	M-24C	-	0.938	1.02	0.16	2.20	1.61	0.30	0.55	1.42	2.09	1.77	1.97	0.09	0.31	0.71	0.0002	0.0003	0.0008
M-28	M-28C	-	1.125	1.57	0.16	3.31	1.81	0.75	0.51	1.73	2.56	2.13	2.17	0.18	0.73	1.63	0.0006	0.0011	0.0027
M-32	M-32C	-	1.250	1.57	0.16	3.31	1.89	0.71	0.51	1.97	2.95	2.48	2.17	0.20	0.95	2.09	0.0010	0.0019	0.0049
M-38	M-38C	-	1.438	1.57	0.16	3.31	1.89	0.71	0.51	2.28	3.27	2.72	2.36	0.29	1.21	2.71	0.0014	0.0031	0.0077
M-42		-	1.653	1.46	0.16	3.46	1.97	0.75	0.51	2.56	3.62	3.07	2.36	0.31	1.50	3.31	0.0021	0.0053	0.0126
M-48	M-48C	-	1.813	1.97	0.16	4.09	1.97	1.06	0.51	2.68	3.74	3.07	2.36	0.51	1.74	3.99	0.0035	0.0064	0.0162
M-65	M-65C	1.024	2.500	2.17	0.16	4.49	2.68	0.91	0.63	3.78	5.20	4.33	2.76	1.21	4.19	9.59	0.0188	0.0281	0.0751
I-80		1.220	3.000	3.54	0.24	7.32	3.66	1.83	0.79	4.88	6.89	5.71	-	2.49	11.47	25.42	0.0610	0.1335	0.3279
I-100		1.496	3.875	4.33	0.31	8.98	4.02	2.48	0.87	5.98	8.27	6.93	-	3.92	20.66	45.25	0.1404	0.3552	0.8508
I-125		1.772	4.813	5.51	0.39	11.42	5.28	3.07	1.18	7.56	10.63	8.86	-	8.56	42.87	94.29	0.4982	1.2058	2.9098

Inch bores machined to AGMA Class 1, Metric bores machined to H7

Order form:	BoWex® M-28	d ₁ Ø 20	d ₂ Ø 28
	Size and design of coupling	Bore	Bore

BoWex® FLE-PA
BoWex® ELASTIC®
MONOLASTIC®

Design AS and design Spec.-I

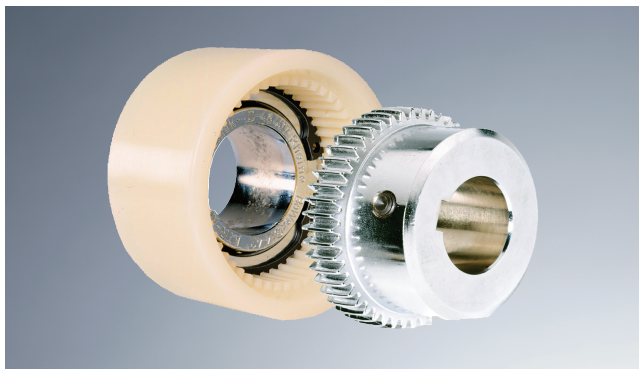

- 1 Non-failsafe, reduced maintenance, blind assembly
- 1 Torsionally stiff
- 1 Compact design for short shaft gaps
- 1 Design AS – Axially movable sleeve when assembled
- 1 Design Spec-I – Sleeve retained for vertical applications
- 1 Installation instructions available at www.ktr.com

Components

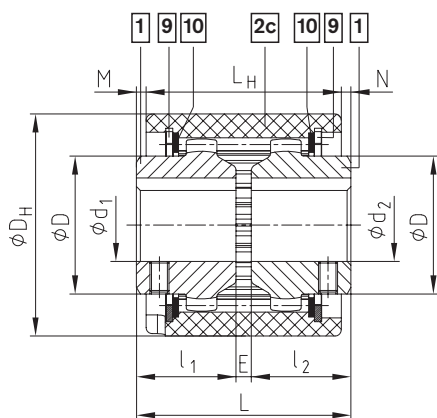

Design AS

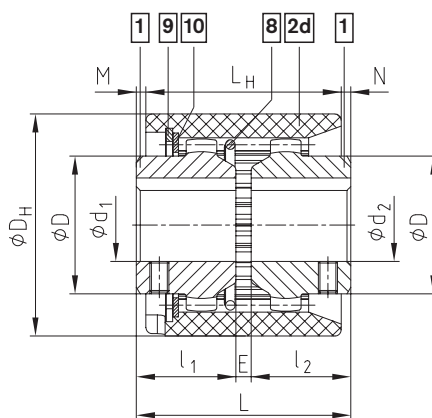

Design Spec. - I

BoWex® design AS and design Spez.-I																	
Size	Bore		Bore d ₁ , d ₂ max.	Dimensions [in]								Weight with max. bore-Ø			Massmoment of inertia J with max. bore-Ø		
	Un- bored	Pilot bored		l ₁ , l ₂	E	L	L _H	M, N	D	D _H	Leng- thened l ₁ , l ₂ max.	Sleeve [lb]	Hub [lb]	Total [lb]	Sleeve [lb-in- sec ²]	Hub [lb-in- sec ²]	Total [lb-in-sec ²]
24	x	-	0.938	1.02	0.16	2.20	2.01	0.10	1.42	2.28	1.97	0.24	0.31	0.86	0.00034	0.00032	0.00097
28	x	-	1.125	1.57	0.16	3.31	2.20	0.55	1.73	2.76	2.17	0.35	0.73	1.81	0.00136	0.00108	0.00352
32	x	-	1.250	1.57	0.16	3.31	2.28	0.51	1.97	3.31	2.17	0.46	0.95	2.36	0.00243	0.00192	0.00628
45	x	-	1.688	1.65	0.16	3.46	2.36	0.55	2.56	3.94	2.36	0.60	1.39	3.37	0.00486	0.00501	0.01488
65	x	1.024	2.500	2.17	0.16	4.49	3.31	0.59	3.78	5.51	2.76	1.85	4.63	11.03	0.02640	0.03891	0.10426
80	-	1.220	3.000	3.54	0.24	7.32	3.66	1.83	4.88	6.89	-	2.87	11.47	25.80	0.07364	0.13347	0.34059
100	-	1.496	3.875	4.33	0.31	8.98	4.02	2.48	5.98	8.27	-	4.52	20.73	45.86	0.16321	0.35519	0.87359
125	-	1.772	4.813	5.51	0.39	11.42	5.28	3.07	7.56	10.63	-	9.53	42.87	95.04	0.54876	1.20577	2.96031

Inch bores machined to AGMA Class 1, Metric bores machined to H7

Order form:	BoWex® 32 AS	d ₁ Ø 32	d ₂ Ø 32
	Size and design of coupling AS or Spec.-I	Bore	Bore

Design SG, design SSR and design Spec.-I/CD

Design SG with dust protection retaining rings

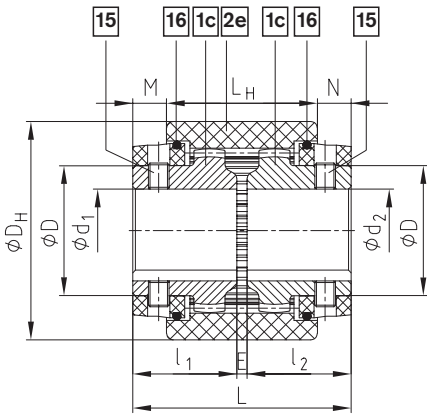

BoWex® design SG												
Size	Pilot bore		Bore		Dimensions [in]							
	Un-bored	Pilot bored	min.	max.	l_1, l_2	E	L	L_H	M, N	D	D_H	Leng- thened l_1, l_2 max.
24 SG	x	-	0.438	0.938	1.42	0.16	2.99	2.01	0.49	1.42	2.28	1.97
28 SG	x	-	0.438	1.125	1.57	0.16	3.31	2.20	0.55	1.73	2.76	2.17
32 SG	x	-	0.500	1.250	1.57	0.16	3.31	2.28	0.51	1.97	3.31	2.17
45 SG	x	-	0.813	1.688	1.65	0.16	3.46	2.36	0.55	2.56	3.94	2.36
65 SG	x	1.024	1.188	2.500	2.76	0.16	5.67	3.31	1.18	3.78	5.51	-
80 SG	-	1.220	1.438	3.000	3.54	0.24	7.32	3.66	1.83	4.80	6.89	-
100 SG	-	1.496	1.625	3.875	4.33	0.31	8.98	4.02	2.48	5.91	8.27	-
125 SG	-	1.772	2.000	4.813	5.51	0.39	11.42	5.28	3.07	7.48	10.63	-

Thread for setscrews only for finish bored hubs.

Design SSR with supporting retaining rings

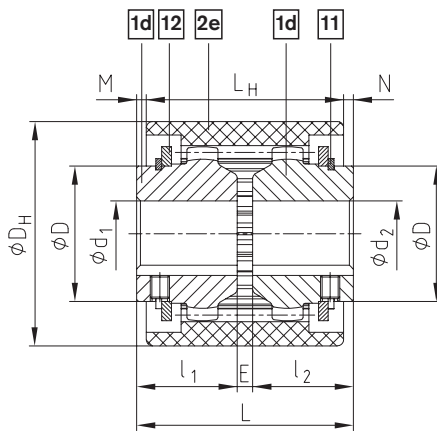

BoWex® design SSR												
Size	Pilot bore		Bore		Dimensions [in]							
	Un-bored	Pilot bored	min.	max.	l_1, l_2	E	L	L_H	M, N	D	D_H	Leng- thened l_1, l_2 max.
24 SSR	x	-	0.438	0.875	1.02	0.16	2.20	2.01	0.10	1.38	2.28	1.97
28 SSR	x	-	0.438	1.000	1.57	0.16	3.31	2.20	0.55	1.65	2.76	2.17
32 SSR	x	-	0.500	1.188	1.57	0.16	3.31	2.28	0.51	1.89	3.31	2.17
45 SSR	x	-	0.813	1.563	1.65	0.16	3.46	2.36	0.55	2.48	3.94	2.36
65 SSR	x	1.024	1.188	2.500	2.17	0.16	4.49	3.31	0.59	3.74	5.51	2.76
80 SSR	-	1.220	1.438	3.000	3.54	0.24	7.32	3.66	1.83	4.72	6.89	-
100 SSR	-	1.496	1.625	3.875	4.33	0.31	8.98	4.02	2.48	5.91	8.27	-
125 SSR	-	1.772	2.000	4.813	5.51	0.39	11.42	5.28	3.07	7.48	10.63	-

Design Spec.-I/CD

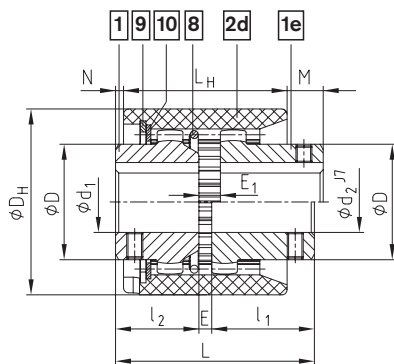

driven side drive side

BoWex® design Spec.-I/CD															
Size	Pilot bore		Bore		Dimensions [in]										
	Un-bored	Pilot bored	min.	max.	L	L_1	L_H	E	E_1	l_2	l_1	D_H	D	M	N
24 CD	x	-	0.438	0.938	2.76	2.89	2.01	0.16	0.30	1.02	1.57	2.28	1.42	0.79	0.10
28 CD	x	-	0.438	1.125	3.72	3.86	2.20	0.16	0.33	1.57	1.99	2.76	1.73	1.10	0.55
32 CD	x	-	0.500	1.250	3.72	-	2.28	0.16	0.33	1.57	1.99	3.31	1.97	1.06	0.51
45 CD	x	-	0.813	1.688	4.00	-	2.36	0.16	0.33	1.65	2.19	3.94	2.56	1.26	0.55
65 CD	-	1.024	1.188	2.500	4.84	-	3.31	0.16	0.39	2.17	2.52	5.51	3.78	1.12	0.59
80 CD	-	1.220	1.438	3.000	7.05	-	3.66	0.24	0.51	3.54	3.27	6.89	4.88	1.73	1.83

Please order dimension sheet of type Spec.-I/CDB with shear pins.

Order form:	BoWex® 45 SG	$d_1 \text{ } \phi 22$	$d_2 \text{ } \phi 40$
	Size and design of coupling SG, SSR or Spec.-I/CD	Bore	Bore

Design SD

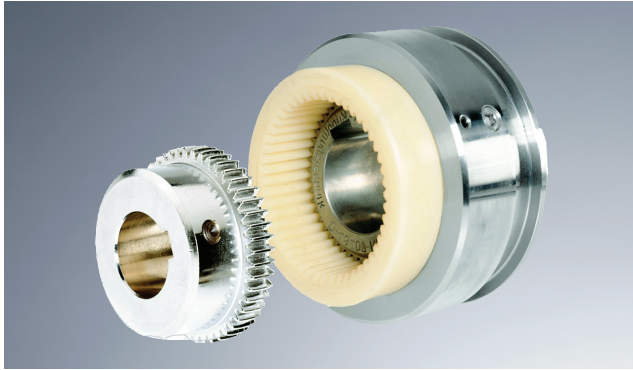

- 1 Non-failsafe, reduced maintenance, blind assembly
- 1 Torsionally stiff
- 1 Shiftable coupling for all applications in general industry
- 1 Easy to engage and disengage drive and driven at standstill
- 1 Spring and ball detent locking mechanism
- 1 Installation instructions available at www.ktr.com

Components

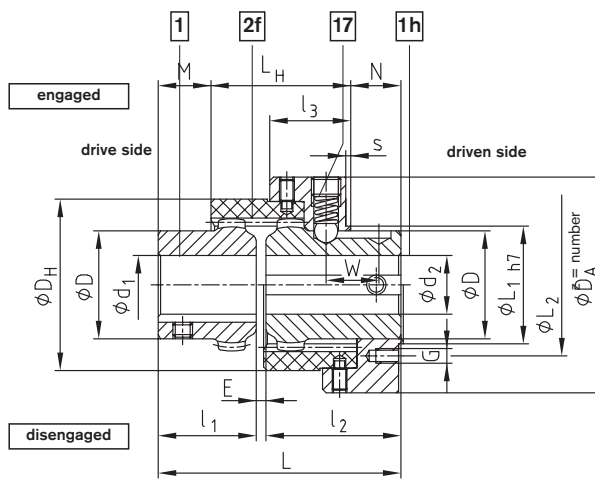

BoWex® design SD																						
Size	Pilot bore		Bore d ₁ , d ₂		Dimensions [in]													Weight with max. bore-Ø		Mass moment of inertia J with max. bore-Ø		Shifting force [lbf]
	Un-bored	Pilot bored	d ₁ max.	d ₂ max.	E	l ₁	l ₂	L	L _H	l ₃	M	W	N	D	D _H	D _A	Shifting hub with sleeve [lb]	Driving hub [lb]	Shifting hub with sleeve [lb-in-sec ²]	Driving hub [lb-in-sec ²]		
24 SD	x	-	0.938	0.938	0.16	1.02	1.97	3.15	2.05	1.22	0.39	0.75	0.71	1.42	2.28	3.07	2.38	0.31	0.0073	0.0003	32	
28 SD	x	-	1.125	1.125	0.16	1.57	2.17	3.90	2.24	1.30	0.85	0.85	0.81	1.73	2.76	3.46	3.31	0.73	0.0138	0.0011	41	
32 SD	x	-	1.250	1.250	0.16	1.57	2.17	3.90	2.28	1.30	0.81	0.85	0.81	1.97	3.31	3.94	4.08	0.95	0.0202	0.0019	41	
45 SD	x	-	1.688	1.688	0.16	1.65	2.36	4.17	2.48	1.46	0.85	0.89	0.85	2.56	3.94	4.92	5.64	1.50	0.0408	0.0050	56	
65 SD	x	1.024	2.500	2.500	0.16	2.17	2.76	5.08	3.03	1.46	1.10	0.98	0.94	3.74	5.51	6.14	11.18	5.07	0.1407	0.0389	79	
80 SD	-	1.220	3.000	3.000	0.24	3.54	3.54	7.32	3.78	1.85	2.20	1.38	1.34	4.88	6.89	7.68	23.37	11.47	0.4635	0.1335	79	
100 SD	-	1.496	3.875	3.875	0.31	4.33	4.33	8.98	4.45	2.17	2.83	1.69	1.69	5.98	8.27	9.25	41.61	20.66	1.1949	0.3552	90	
125 SD	-	1.772	4.813	4.813	0.39	5.51	5.51	11.42	5.87	2.76	3.50	2.05	2.05	7.56	10.63	11.73	89.08	20.82	4.3538	1.2058	101	

Inch bores machined to AGMA Class 1, Metric bores machined to H7

Connection dimensions of BoWex® SD shifting ring (part 17) for mounting of: slip ring SD1 (s catalog page 85), shifting disc etc.				
Size	Dimensions [in]			
	L ₁	L ₂	z x G	s
24 SD	1.89	2.28	4xM6	0.08
28 SD	1.89	2.28	4xM6	0.08
32 SD	2.52	2.95	4xM6	0.08
45 SD	2.95	3.54	4xM8	0.08
65 SD	3.94	4.49	4xM8	0.08
80 SD	5.12	5.71	4xM8	0.12
100 SD	7.09	7.72	6xM10	0.16
125 SD	8.66	9.29	6xM10	0.16

Order form:	BoWex® 32 SD	d ₁ Ø 32	d ₂ Ø 32
	Size and design of coupling	Bore	Bore

Design SD1



- 1 Non-failsafe, reduced maintenance, blind assembly
- 1 Torsionally stiff
- 1 Shiftable coupling for all applications in general industry
- 1 Easy to engage and disengage drive and driven at standstill
- 1 Optional shiftable linkage kit available to ease installation
- 1 Spring and ball detent locking mechanism
- 1 Installation instructions available at www.ktr.com

BoWex®
MONOELASTIC®
BoWex® - FLE-PA
BoWex® - ELASTIC®

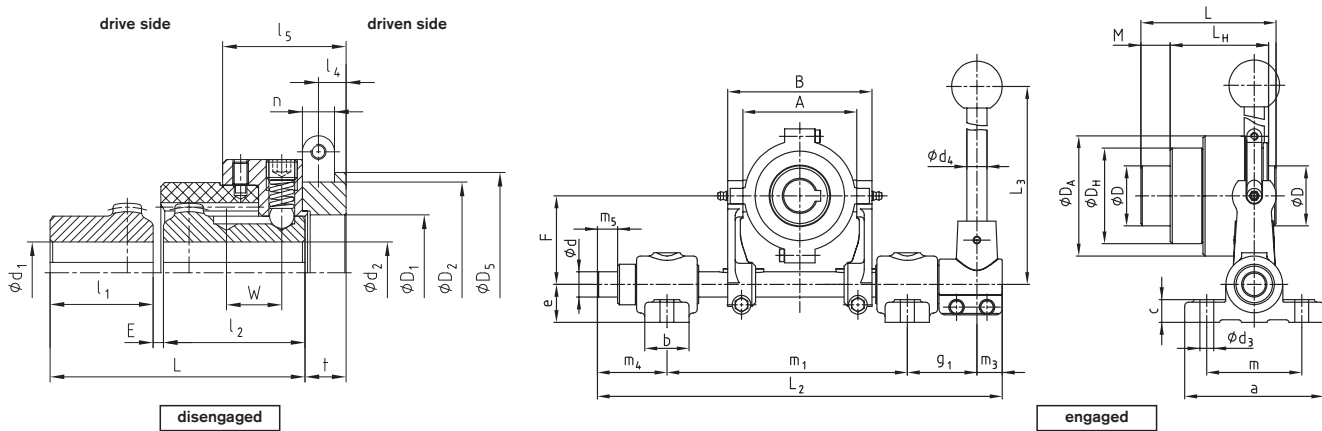

BoWex® design SD1 and slip ring																					
Size	Bore		Dimensions [in]																		Shifting force [lbf]
	d ₁ max.	d ₂ max.	E	l ₁	l ₂	L	L _G	l ₄	l ₅	M	W	t	D	D _H	D _A	D ₁	D ₂ ^{±0.004} (keyway)	D ₅	n ^{±0.004} (keyway)		
24 SD1	0.938	0.938	0.16	1.02	1.97	3.15	2.64	0.43	1.81	0.39	0.75	0.63	1.42	2.28	3.07	1.77	2.78	3.07	0.49	32	
28 SD1	1.125	1.125	0.16	1.57	2.17	3.90	2.83	0.43	1.89	0.85	0.85	0.63	1.73	2.76	3.46	1.77	2.78	3.07	0.49	41	
32 SD1	1.250	1.250	0.16	1.57	2.17	3.90	3.07	0.53	2.09	0.81	0.85	0.83	1.97	3.31	3.94	2.36	3.52	3.94	0.69	41	
45 SD1	1.688	1.688	0.16	1.65	2.36	4.17	3.31	0.55	2.28	0.85	0.89	0.87	2.56	3.94	4.92	2.76	4.43	4.92	0.71	56	
	1.813			4.49		1.16															
65 SD1	2.500	2.500	0.16	2.17	2.76	5.08	4.06	0.63	2.40	1.02	0.98	0.98	3.78	5.51	6.14	3.78	5.14	5.71	0.81	79	
80 SD1	3.000	3.000	0.24	3.54	3.54	7.32	4.88	0.73	2.95	2.20	1.38	1.14	4.88	6.89	7.68	4.92	6.48	7.17	1.00	79	
100 SD1	3.875	3.875	0.31	4.33	4.33	8.98	5.98	1.10	3.70	2.83	1.69	1.54	5.98	8.27	9.25	6.85	8.29	9.06	1.20	90	
125 SD1	4.813	4.813	0.39	5.51	5.51	11.42	7.60	1.20	4.49	3.50	2.05	1.73	7.56	10.63	11.73	8.43	9.86	10.83	1.40	101	

Inch bores machined to AGMA Class 1, Metric bores machined to H7

BoWex® SD1 – shiftable linkage																					
Size	Shiftable linkage size	Slip ring size	Dimensions [in]																	Dimensions with m ₁ max.	
			a	b	c	d	d ₃	d ₄	e	F	g ₁	L ₂	L ₃	m	m ₁ min.	m ₁ max.	A	B	m ₃	m ₄	m ₅
24 SD1	1	1.1	4.33	1.38	0.71	0.79	0.43	0.63	1.18	2.76	2.17	12.60	15.75	2.95	7.09	7.48	3.54	4.49	0.79	3.15	1.34
28 SD1	1																				
32 SD1	2	2.2								3.84	2.36	16.93	17.72		9.45	10.63	4.37	5.94			
45 SD1	3	3.3	5.51	2.36				0.79	1.57	4.72		19.29	23.62	3.94	11.02	12.20	5.51	7.09		3.54	1.73
65 SD1	3	4.4			0.98						2.76				6.69	8.27					
80 SD1	4	5.5							1.97	5.81		22.24	29.53		12.64	14.37	7.87	9.61		3.94	2.13
100 SD1	5	6.6	6.30	2.36				1.18	1.97	7.48	3.15	24.80	42.05	4.72	14.37	16.14	9.84	11.81	1.18	4.33	2.44
125 SD1	5	7.7													-		11.81	13.78			

1) = For a one-piece base plates dimension "e" has to be increased by at least 0.40 in by shims or other suitable means.

Order form:	BoWex® 65 SD1	d ₁ Ø 32	d ₂ Ø 32	4.4	3
	Size and design of coupling	Bore		Slip ring size	Shiftable linkage size

Made from corrosion-proof material



- 1 Non-failsafe, reduced maintenance, blind assembly
- 1 Torsionally stiff
- 1 Corrosion resistant all polyamide or stainless steel construction
- 1 Suitable for general drive applications
- 1 Compact design for short shaft gaps
- 1 Installation instructions available at www.ktr.com

Components

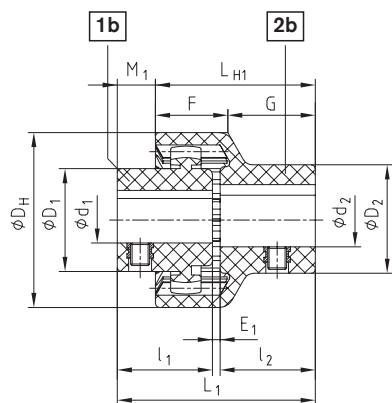

Design junior plug-in coupling

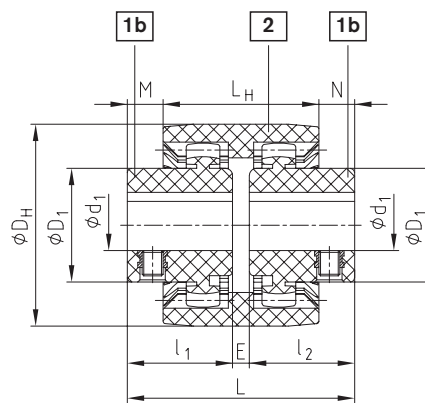

Design junior M coupling

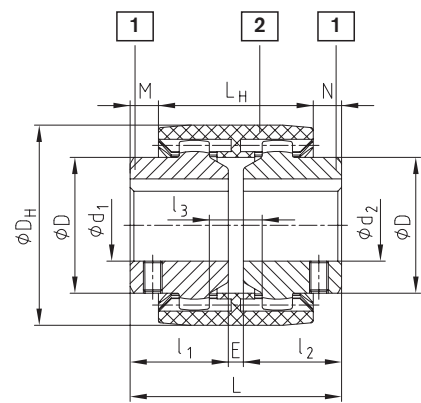

Design M

BoWex® junior plug-in coupling (2 parts) and BoWex® junior M (3 parts)

Size	Available bore				Dimensions [in]										
	Hub part 1b d_1	D_1	Plug-in-sleeve part 2b d_2	D_1	D_H	l_1, l_2	E_1	E	L_{H1}	L_H	L_1	L	M_1	M, N	
14	0.236, 0.276, 0.315, 0.354	0.87	0.315	0.87											
M-14	0.394, 0.433	0.98	0.394, 0.433	0.98	1.57	0.91	0.08	0.16	1.57	1.46	1.89	1.97	0.31	0.26	
	0.472, 0.551	1.02	0.472, 0.551	1.02											
19	0.472, 0.551	1.06	0.551, 0.591	1.14											
M-19	0.630	1.18			1.89	0.98	0.08	0.16	1.65	1.46	2.05	2.13	0.39	0.33	
	0.748	1.26	0.748	1.38											
24	0.394, 0.433, 0.472	1.02	0.551, 0.630	1.26											
M-24	0.551, 0.591, 0.630	1.26			2.09	1.02	0.08	0.16	1.77	1.61	2.13	2.20	0.35	0.30	
	0.709, 0.748, 0.787	1.42	0.748, 0.787	1.42											
	0.945	1.50	0.945	1.57											

Inch bores machined to AGMA Class 1, Metric bores machined to H7

BoWex® design M

Size	Bore d_{1max}, d_{2max}	Dimensions [in]						
		D_H	D	l_1, l_2	E	L_H	L	M, N
M-24	0.938	2.09	1.42	1.02	0.16	1.61	2.20	0.30
M-38	1.438	3.27	2.28	1.57	0.16	1.89	3.31	0.71
M-48	1.813	3.74	2.68	1.97	0.16	1.97	4.09	1.06

Additional sizes on request.

Applications:

Food processing industry, print and paper, textile industry, sewage technology, mobile washers, chemical, pharmaceutical industry and aggressive environments (air, water, chemicals etc.).

Order form:

BoWex® M-24 V4A	$d_1 \text{ } \varnothing 20$	$d_2 \text{ } \varnothing 24$
Size and design of coupling	Bore	Bore

Operating description

MONOLASTIC®



General description:

MONOLASTIC® – couplings are designed to transmit torque on flywheel driven applications via a one-piece design. This design features a plug-in assembly that provides considerable system dampening for low driven inertias. This product is available in SAE and Metric flywheel configurations.

Function and Design

MONOLASTIC® - couplings are constructed from materials designed to provide a torsionally flexible solution in an easy to assemble one-piece design. The rubber element allows for misalignment and some dampening while reducing restoring forces on driven components. The flexible one-piece design enables a compact assembly while reducing the likelihood of fretting and premature wear of the spline connection.

MONOLASTIC® is available in a variety of standard mounting options to accommodate flywheels up to SAE 11.5" and a maximum of 185 HP nominal in a plug-in design. They are also available in metric, and engine specific configurations. They are suitable for low inertia drives typically found in hydrostatic applications.

BoWex® FLE-PA

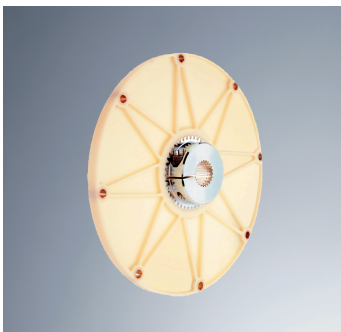

General description:

BoWex® FLE-PA – couplings are designed to transmit torque on flywheel driven applications via a curved tooth hub and nylon engine flange. The combination of these components provides a torsionally stiff connection for low driven inertias. This product is available in materials and elements that are optimized for close coupled applications.

Function and Design

BoWex® FLE-PA - couplings, intended for flywheel driven applications, are constructed from materials designed to provide a torsionally stiff solution while optimizing the balance between coupling performance and ease of assembly. The double-crowned tooth reduces edge loading while accommodating misalignments and transmitting torque. The compact two-piece coupling design enables the hub to be securely fastened to the driven shaft eliminating the need for lubrication, reducing fretting and corrosion, while allowing for minimal maintenance in an engine drive coupling.

The two-piece design of the BoWex® FLE-PA allows the nylon flange to provide high stiffness, low inertia, corrosion resistance, and allows for blind assembly. Nylon flanges are available from stock in standard SAE, metric and engine specific configurations.

BoWex® FLE-PA is available in a variety of standard mounting options to accommodate flywheels up to SAE 18" and a maximum of 1,075 HP nominal, while still accommodating blind assembly. They are suitable for low inertia drives typically found in hydrostatic applications.

BoWex-ELASTIC®



General description:

BoWex-ELASTIC® – couplings are designed to transmit torque on flywheel driven applications via a curved tooth hub and elastomeric engine flange. The combination of these components provides a highly flexible connection for large driven inertias. The torsionally flexible connection modifies the torsional profile of the system, moving critical resonance out of the operating range.

Function and Design

BoWex-ELASTIC® - couplings are intended for engine driven high inertia applications. Constructed from natural rubber, the coupling design provides a highly flexible solution while optimizing the balance between coupling performance and ease of assembly. The two-piece coupling design enables the hub to be securely fastened to the driven shaft, eliminating the need for lubrication, reducing fretting and corrosion, while allowing for minimal maintenance in an engine drive coupling.

BoWex-ELASTIC® elements are available in several hardnesses. When the proper hardness is selected, maximum benefit can be achieved between dampening and torque transmission, insuring proper torsional profile for your application. Elastic elements are available in standard SAE and metric sizes.

BoWex-ELASTIC® is available in a variety of standard mounting options to accommodate flywheels up to SAE 18" and a maximum of 1,500 HP nominal. They are suitable for high inertia drives typically found in compressors, pumps and generators.